

SEAGULL®

SERIES

$\emptyset 2,07 \pm 0,02$

$(\emptyset 1,57 \pm 0,02)$

außergewöhnlich.

STABLE.

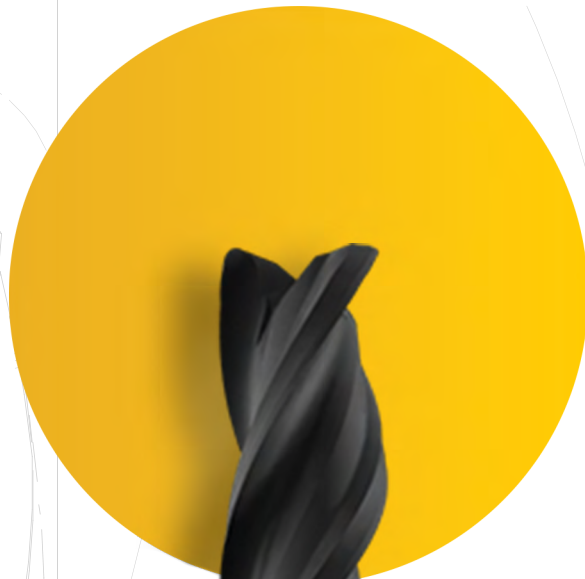

Z ZECHA

anzahlheit A



ZECHA
außergewöhnlich.

SEAGULL®
SERIES

$\varnothing 1 \pm 0.001^{\circ}$

0,95



SEAGULL® SERIES

INNOVATIONS FOR GRAPHITE MACHINING

Discover the revolution in graphite machining with SEAGULL® end mills! Milling graphite electrodes plays a crucial role in tool and mold making. With state-of-the-art machines, even the finest 3D contours in the micron range can be accurately produced.

To fully exploit this potential, highly precise diamond-coated tools with exact shape and concentricity are essential. Our SEAGULL® end mills are setting new standards: With their unique combination of specially selected carbide grades, optimized geometry, precise grinding, and perfectly adapted diamond coating, they are the ideal

companions in the production of highly complex graphite electrodes.

The extremely short flute of the SEAGULL® end mills enables easy milling of graphite and other hard-brittle non-ferrous materials in both dry and wet machining.

Immerse yourself in the future of graphite machining with SEAGULL® end mills and experience groundbreaking innovations!

SEAGULL®
SERIES

$\varnothing 1 \pm 0.001^{\circ}$
0,95

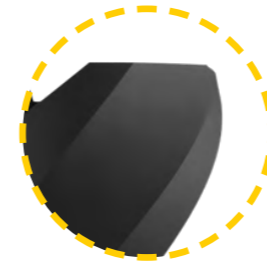

PATENTED CUTTING GEOMETRY

INNOVATION FOR LONG-LASTING PRECISION

The SEAGULL® end mills impress with extremely tight tolerances. Each tool is carefully measured, and the packaging label is provided with the actual values to ensure the highest precision.

New to the SEAGULL® family, we proudly present the end mill with corner radius 576.T3. With its three flutes, it is an absolute rarity in the market. Its unique combined geometry enables high chip-removal rates during roughing, while also offering finest engagement conditions for finishing.

The SEAGULL® quality end mills of the 568 and 578 series are designed for price-conscious users who still demand excellent quality.

With the innovations of the SEAGULL® series, you experience precision and performance in perfection!

* The series 567/568, 577/578, and 576.T3 shown are protected by Patent EP 2540427B1 in the following countries: DE, AT, CH, LIE, CZ, FR, GB, IT, NL, PL, PT, TR.

* The series 576.T3 shown is additionally protected by Patent DE 10 2019 122 039 B3 in Germany.

SEAGULL®
SERIES

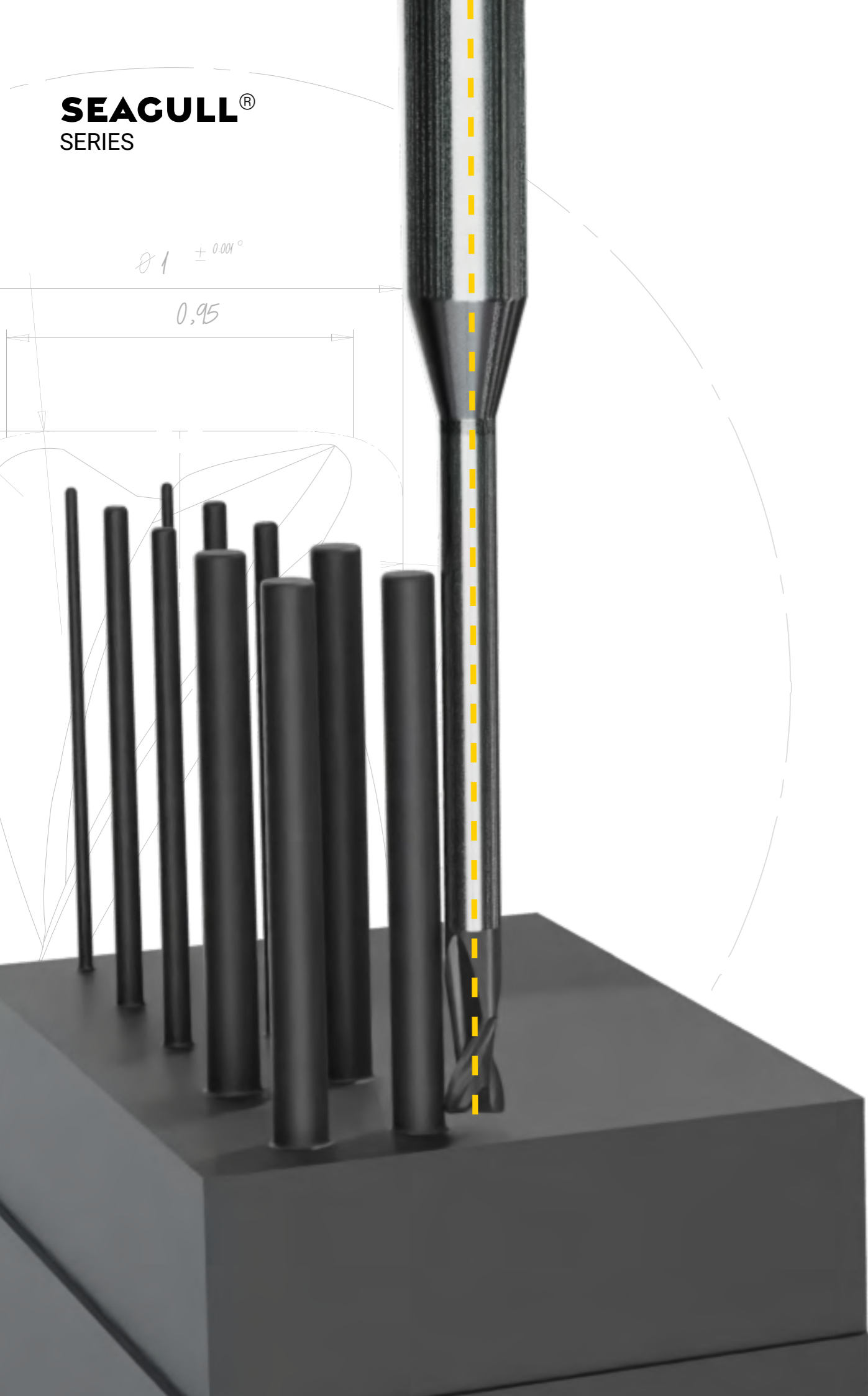

INNOVATIVE CUTTING GEOMETRY

REDUCED DEFLECTION THANKS TO PATENT

Our patented cutting-edge geometry revolutionizes milling operations by significantly reducing tool deflection. Here's how:

A fine cutting edge recession greatly reduces cutting pressure, which in turn minimizes tool deflection. This enables the machining of sensitive, narrow component areas, ribs, or pins without the need for "re-cutting" or the risk of significant vibrations and increased risk of breakage.

The outstanding dimensional and shape stability, concentricity, and low-vibration cutting guidance help minimize cutting forces and reduce deflection. This is particularly important for large tool overhang lengths from 5xD to 20xD.

Trust in our innovative solutions, which not only increase your productivity but also ensure the safety and precision of your machining processes.

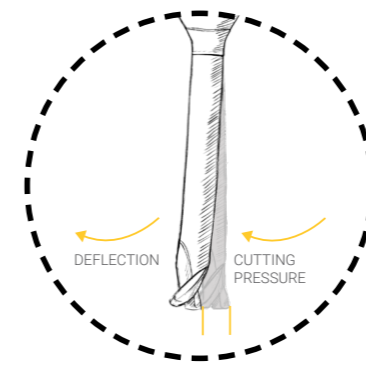

Conventional tool

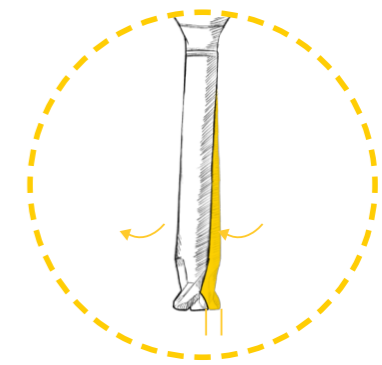

SEAGULL®

SEAGULL®
SERIES

$\varnothing 1 \pm 0.001^{\circ}$

0,95



SHORT FINISHING AND LONG ROUGHING FLUTES

MULTIPLE STEPS WITH ONE TOOL

Our revolutionary geometry of the 576.T3 end mills with corner radius sets new standards in milling operations by combining roughing and finishing flutes in one tool. Multiple machining steps can thus be performed with just one tool. The roughing flute allows for rapid chip removal, while the finishing flute ensures fine surfaces and precise finishing.

When roughing vertical component areas with the entire 2xD cutting length, the minimally "protruding" 0.5xD finishing flute leaves a small step in

the dimension of the component. The subsequent finishing with finer depth increments (maximum a_p = corner radius of the mill) then achieves the cylindrical, dimensionally accurate, and fine component surface.

With the 2-in-1 cutting geometry, you maximize the efficiency of your machining processes while simultaneously achieving outstanding surface quality and precision.

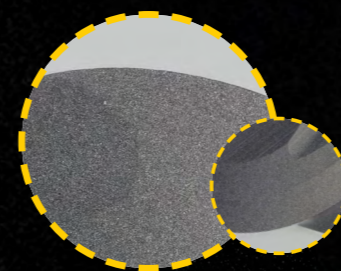
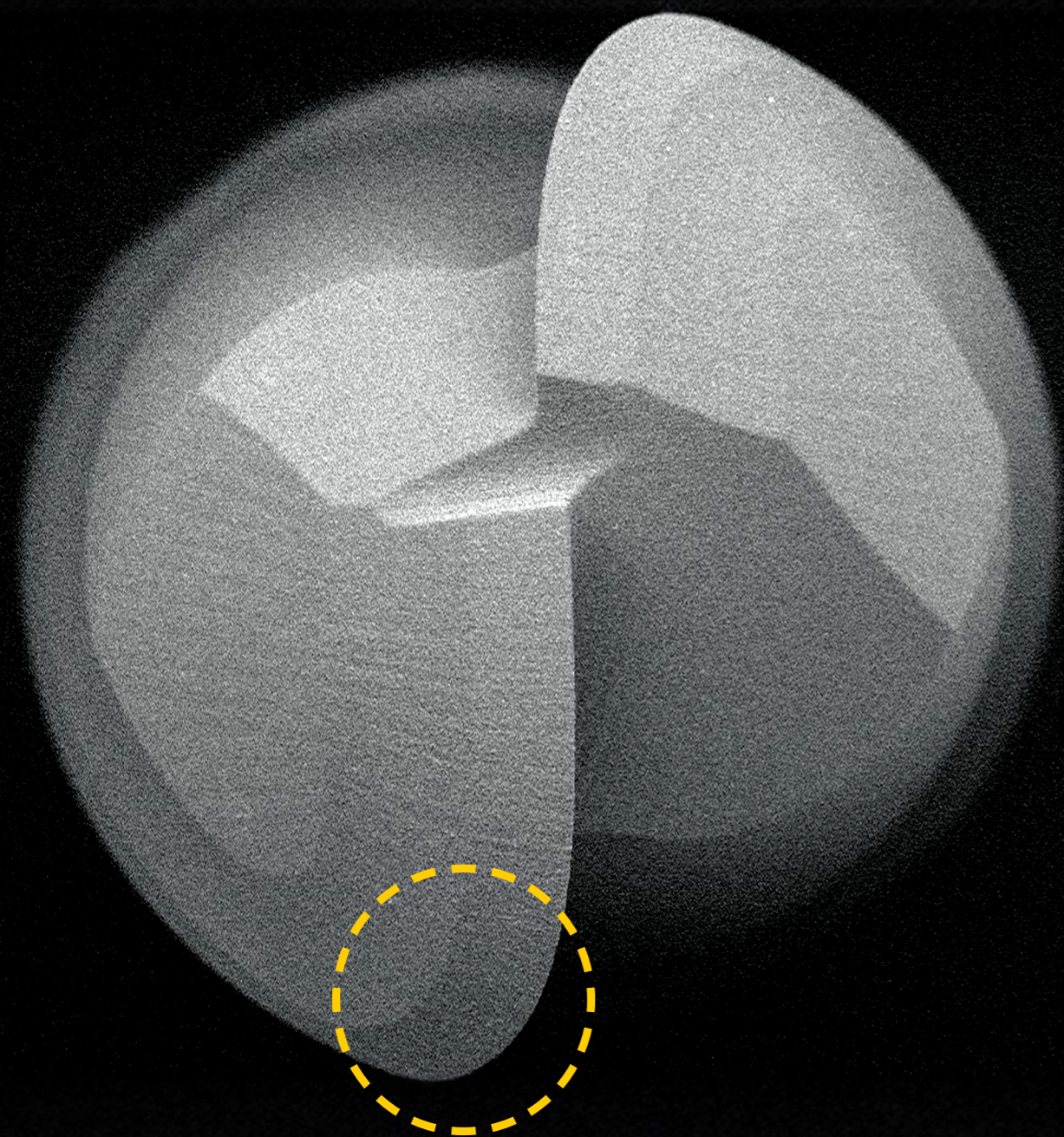

DIAMOND COATING

IN APPLICATION-SPECIFIC LAYER THICKNESSES

Our diamond coating redefines the standards for high-demand tools. With an extremely high hardness of about 10,000 HV, diamond offers unbeatable wear resistance and reliability.

In collaboration with renowned coating experts, we guarantee the highest quality. Our diamond coating is perfectly tailored to the geometry and material properties, allowing for tremendous dimensional accuracy of +/- 5 µm, which is reliably reproducible. The coating thickness is consistently uniform, without clustering at the cutting edge.

The Seagull® coating not only provides a homogeneous surface for consistent results on the component but also offers excellent geometric flexibility. Discover the advantages of high-quality diamond coating and be a part of our success story.

SEAGULL®
SERIES

$\varnothing 1 \pm 0.001^{\circ}$

0,95

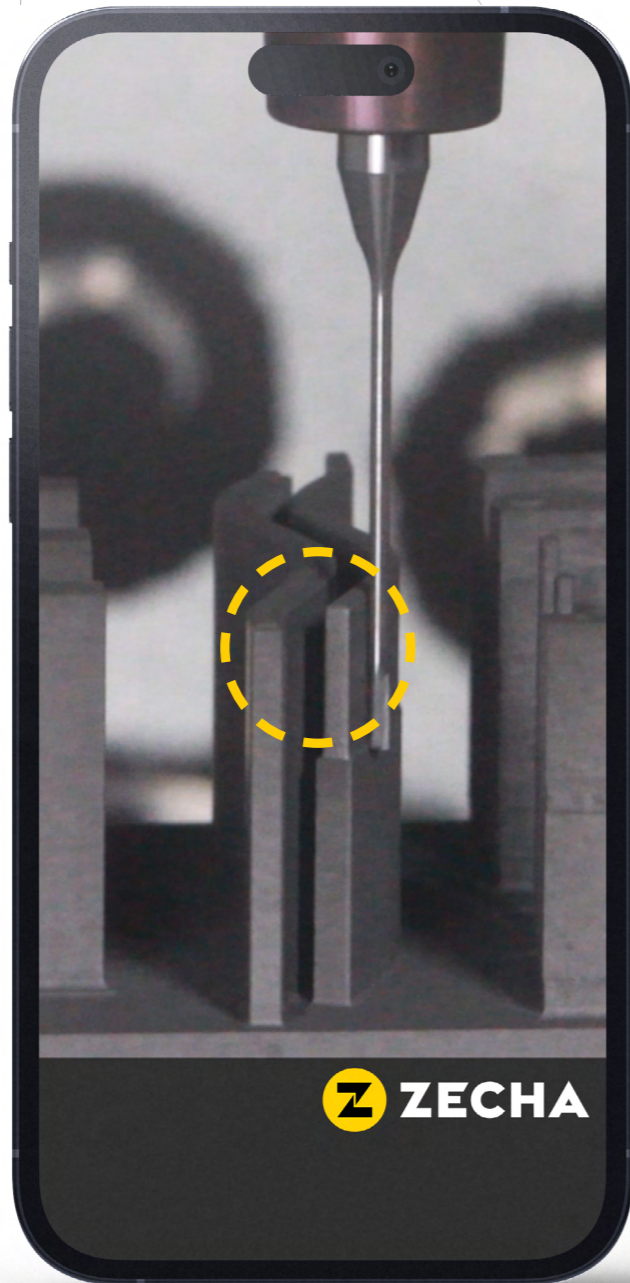

SEE IT IN ACTION

MILLING EXAMPLE IN GRAPHITE

Curious to see SEAGULL® tool technology in action? It's as easy as scanning the QR code below. With just a quick scan, you'll find yourself on a YouTube video where SEAGULL® tools skillfully mill a graphite electrode. Watch and explore the effortless precision and durability that defines the SEAGULL® Series, and get a glimpse of the future of tooling.



SEAGULL® SERIES

SERIES OPTIONS

Numerous variations are available in the SEAGULL® Series, which we will break down for you below. Here you will find a brief explanation of the different tool series as well as relevant symbols for the properties of the tools. More information about the series and a key explaining the different symbols can be found on the following pages.

567 SERIES

Solid carbide 2-flute ball-nose end mill with corner radius, 30° helix angle, high-performance diamond coating.

568 SERIES

Solid carbide 2-flute ball-nose end mill, 30° helix angle, basic diamond coating.

576.T3 SERIES

Solid carbide 3-flute end mill with corner radius, 30° helix angle, high-performance diamond coating, 2-in-1 roughing/finishing design.

577 SERIES

Solid carbide 2-flute end mill with corner radius, 30° helix angle, high-performance diamond coating.

578 SERIES

Solid carbide 2-flute end mill with corner radius, 30° helix angle, basic diamond coating.

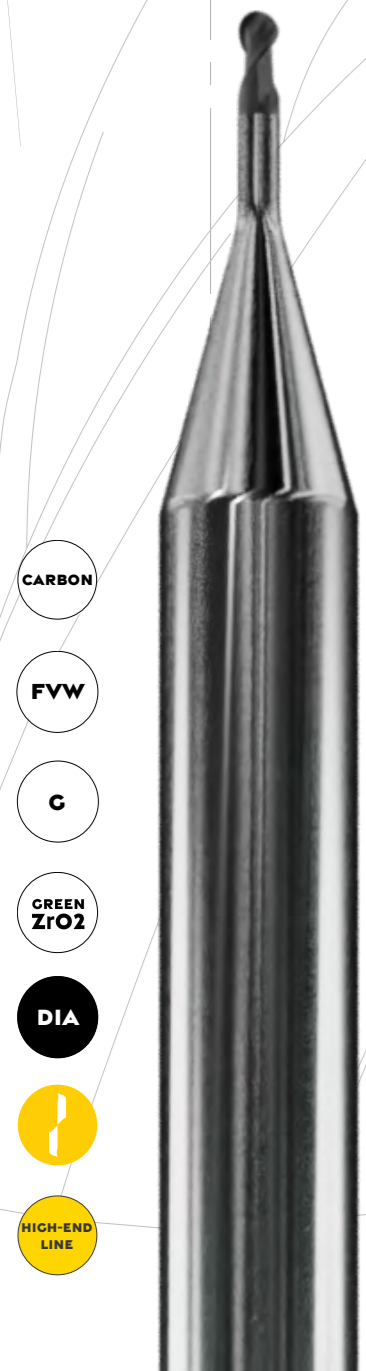

- CARBON
- FVW
- C
- GREEN ZrO2
- DIA
- HIGH-END LINE



- CARBON
- FVW
- C
- GREEN ZrO2
- DIA
- QUALITY LINE



- CARBON
- FVW
- C
- GREEN ZrO2
- DIA
- 2-IN-1
- HIGH-END LINE



- CARBON
- FVW
- C
- GREEN ZrO2
- DIA
- HIGH-END LINE



- CARBON
- FVW
- C
- GREEN ZrO2
- DIA
- QUALITY LINE

On the following pages you will find further information on the technical data and available options for each series, as well as a QR code to obtain a direct link to the corresponding tool in the ZECHAshop.

SEAGULL® SERIES

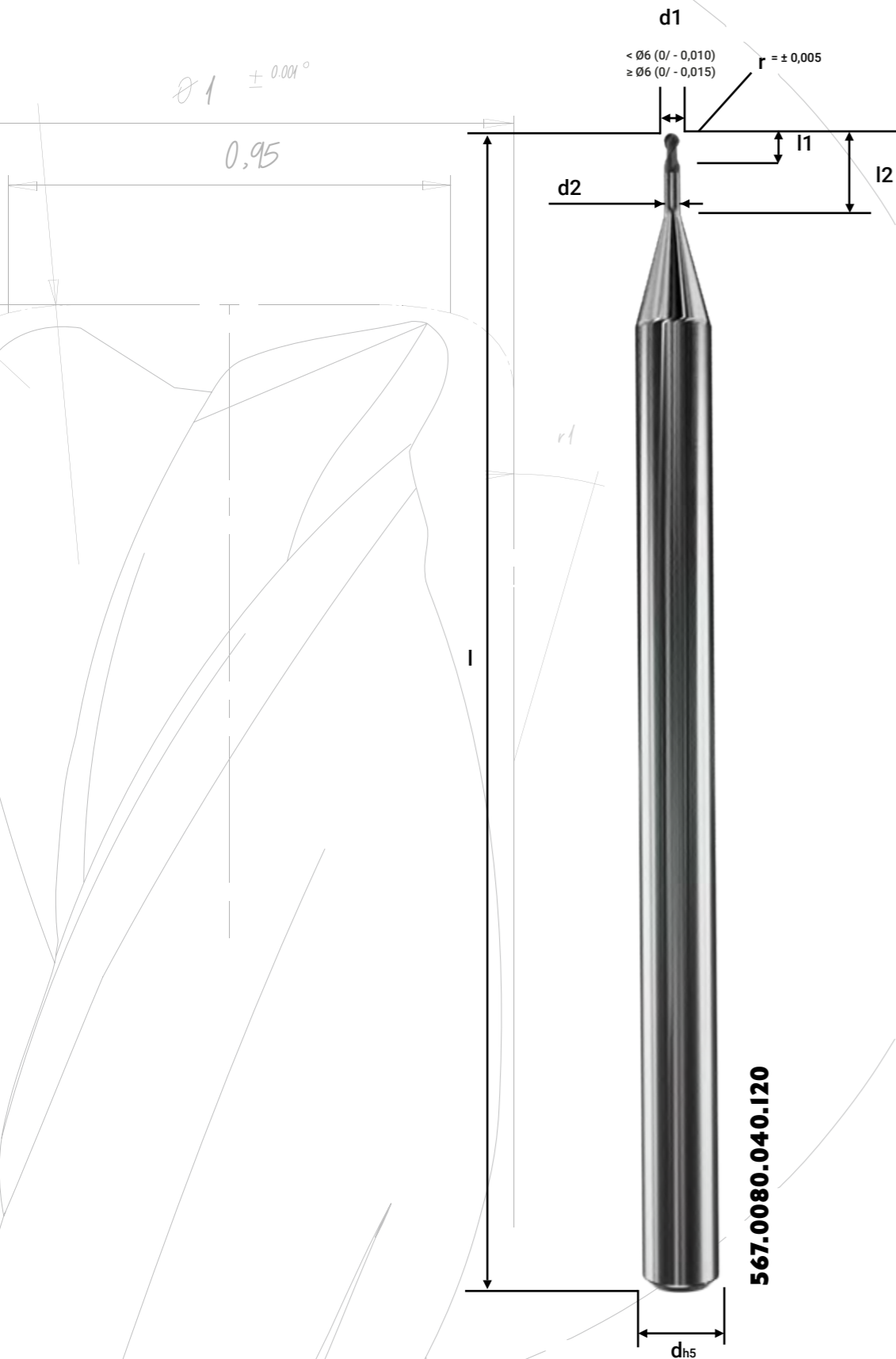

SEAGULL® 567 SERIES

- Solid carbide 2-flute ball-nose end mill with a 30° helix angle
- Patented flute exposure EP 2 540 427 B1*
- Short cutting flute < 0.5 x D
- High-performance diamond coating
- For dry or wet roughing/semi-finishing/finishing



Article No.	d1	d2	r	l1	l2	d	l
567.0030.015.015	0.3	0.25	0.15	0.20	1.5	4.0	40
567.0030.015.030	0.3	0.25	0.15	0.20	3.0	4.0	40
567.0030.015.045	0.3	0.25	0.15	0.20	4.5	4.0	40
567.0030.015.060	0.3	0.25	0.15	0.20	6.0	4.0	40
567.0040.020.020	0.4	0.35	0.20	0.30	2.0	4.0	40
567.0040.020.040	0.4	0.35	0.20	0.30	4.0	4.0	40
567.0040.020.060	0.4	0.35	0.20	0.30	6.0	4.0	40
567.0040.020.080	0.4	0.35	0.20	0.30	8.0	4.0	40
567.0050.025.025	0.5	0.45	0.25	0.35	2.5	4.0	60
567.0050.025.050	0.5	0.45	0.25	0.35	5.0	4.0	60
567.0050.025.075	0.5	0.45	0.25	0.35	7.5	4.0	60
567.0050.025.100	0.5	0.45	0.25	0.35	10.0	4.0	60
567.0060.030.030	0.6	0.55	0.30	0.40	3.0	4.0	60
567.0060.030.060	0.6	0.55	0.30	0.40	6.0	4.0	60
567.0060.030.090	0.6	0.55	0.30	0.40	9.0	4.0	60
567.0060.030.120	0.6	0.55	0.30	0.40	12.0	4.0	60
567.0080.040.040	0.8	0.75	0.40	0.50	4.0	4.0	60
567.0080.040.080	0.8	0.75	0.40	0.50	8.0	4.0	60
567.0080.040.120	0.8	0.75	0.40	0.50	12.0	4.0	60
567.0080.040.160	0.8	0.75	0.40	0.50	16.0	4.0	60
567.0100.050.050	1.0	0.95	0.50	0.80	5.0	4.0	60
567.0100.050.100	1.0	0.95	0.50	0.80	10.0	4.0	60
567.0100.050.150	1.0	0.95	0.50	0.80	15.0	4.0	60
567.0100.050.200	1.0	0.95	0.50	0.80	20.0	4.0	60
567.0120.060.150	1.2	1.15	0.60	0.90	15.0	4.0	60
567.0120.060.200	1.2	1.15	0.60	0.90	20.0	4.0	60

*Patented in DE, AT, CH, LIE, CZ, FR, GB, IT, NL, PL, PT, TR

continued on next page...

SEAGULL®
SERIES

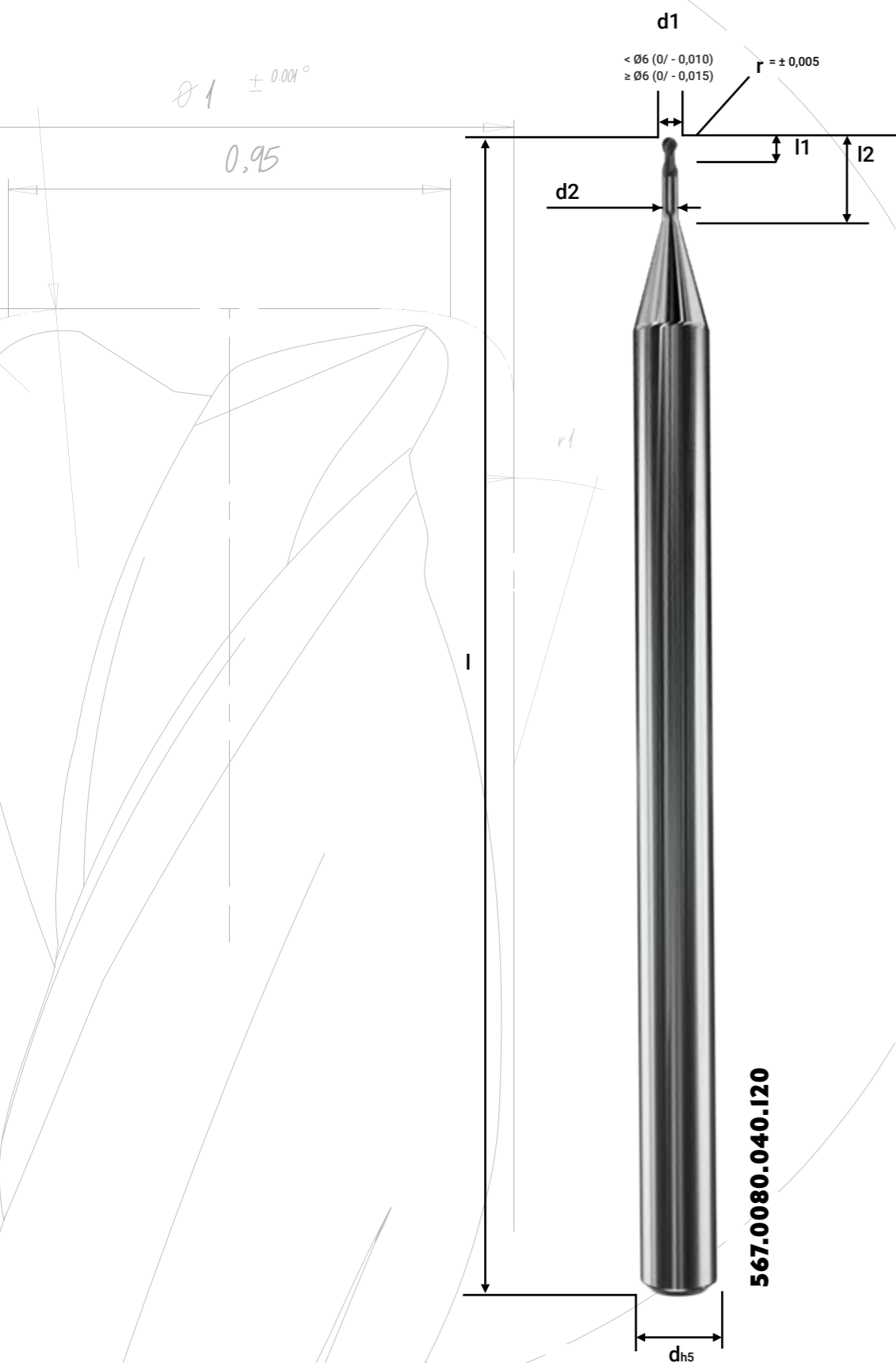

SEAGULL® 567 SERIES...CONTINUED

Article No.	d1	d2	r	l1	l2	d	l
567.0150.075.100	1.5	1.40	0.75	1.05	10.0	4.0	60
567.0150.075.150	1.5	1.40	0.75	1.05	15.0	4.0	60
567.0150.075.200	1.5	1.40	0.75	1.05	20.0	4.0	60
567.0150.075.250	1.5	1.40	0.75	1.05	25.0	4.0	60
567.0200.100.120	2.0	1.90	1.00	1.30	12.0	4.0	60
567.0200.100.180	2.0	1.90	1.00	1.30	18.0	4.0	60
567.0200.100.200	2.0	1.90	1.00	1.30	20.0	4.0	60
567.0200.100.240	2.0	1.90	1.00	1.30	24.0	4.0	60
567.0200.100.300	2.0	1.90	1.00	1.30	30.0	4.0	60
567.0300.150.120	3.0	2.80	1.50	1.80	12.0	6.0	60
567.0300.150.180	3.0	2.80	1.50	1.80	18.0	6.0	60
567.0300.150.240	3.0	2.80	1.50	1.80	24.0	6.0	60
567.0300.150.300	3.0	2.80	1.50	1.80	30.0	6.0	70
567.0400.200.300	4.0	3.80	2.00	2.50	30.0	6.0	60
567.0400.200.400	4.0	3.80	2.00	2.50	40.0	6.0	70
567.0600.300.450	6.0	5.80	3.00	3.50	45.0	6.0	80
567.0600.300.700	6.0	5.80	3.00	3.50	70.0	6.0	100
567.0800.400.850	8.0	7.80	4.00	4.50	85.0	8.0	120
567.1000.500.850	10.0	9.80	5.00	5.50	85.0	10.0	120

SEAGULL®
SERIES

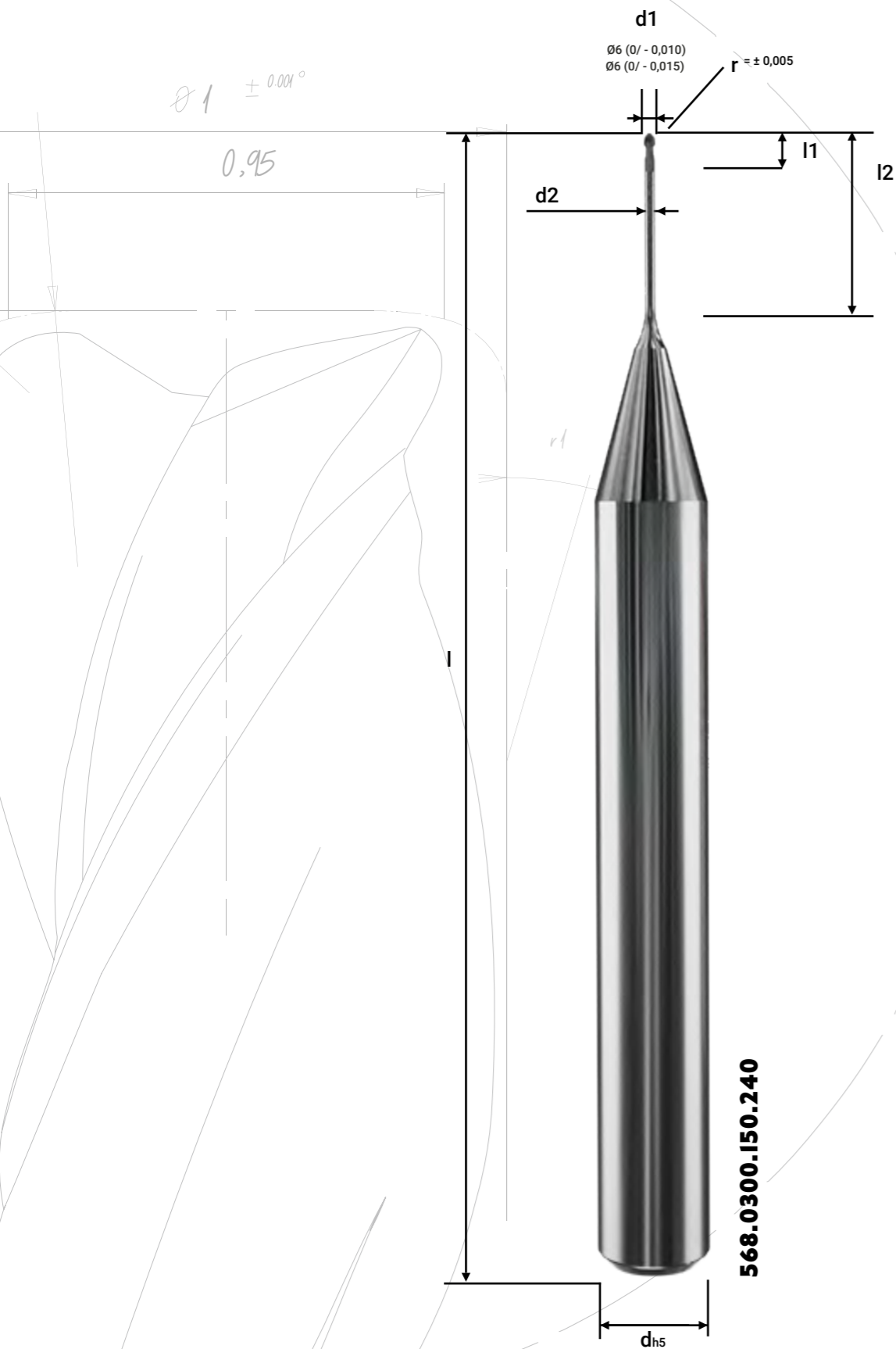

SEAGULL® 568 SERIES

- Solid carbide 2-flute ball-nose end mill with a 30° helix angle
- Patented flute exposure EP 2 540 427 B1*
- Short cutting flute < 0.5 x D
- Basic diamond coating
- For dry or wet roughing/semi-finishing/finishing



Article No.	d1	d2	r	l1	l2	d	l
568.0030.015.015	0.3	0.25	0.15	0.20	1.5	4.0	40
568.0030.015.030	0.3	0.25	0.15	0.20	3.0	4.0	40
568.0030.015.045	0.3	0.25	0.15	0.20	4.5	4.0	40
568.0030.015.060	0.3	0.25	0.15	0.20	6.0	4.0	40
568.0040.020.020	0.4	0.35	0.20	0.30	2.0	4.0	40
568.0040.020.040	0.4	0.35	0.20	0.30	4.0	4.0	40
568.0040.020.060	0.4	0.35	0.20	0.30	6.0	4.0	40
568.0040.020.080	0.4	0.35	0.20	0.30	8.0	4.0	40
568.0050.025.025	0.5	0.45	0.25	0.35	2.5	4.0	60
568.0050.025.050	0.5	0.45	0.25	0.35	5.0	4.0	60
568.0050.025.075	0.5	0.45	0.25	0.35	7.5	4.0	60
568.0050.025.100	0.5	0.45	0.25	0.35	10.0	4.0	60
568.0060.030.030	0.6	0.55	0.30	0.40	3.0	4.0	60
568.0060.030.060	0.6	0.55	0.30	0.40	6.0	4.0	60
568.0060.030.090	0.6	0.55	0.30	0.40	9.0	4.0	60
568.0060.030.120	0.6	0.55	0.30	0.40	12.0	4.0	60
568.0080.040.040	0.8	0.75	0.40	0.50	4.0	4.0	60
568.0080.040.080	0.8	0.75	0.40	0.50	8.0	4.0	60
568.0080.040.120	0.8	0.75	0.40	0.50	12.0	4.0	60
568.0080.040.160	0.8	0.75	0.40	0.50	16.0	4.0	60
568.0100.050.050	1.0	0.95	0.50	0.80	5.0	4.0	60
568.0100.050.100	1.0	0.95	0.50	0.80	10.0	4.0	60
568.0100.050.150	1.0	0.95	0.50	0.80	15.0	4.0	60
568.0100.050.200	1.0	0.95	0.50	0.80	20.0	4.0	60

*Patented in DE, AT, CH, LIE, CZ, FR, GB, IT, NL, PL, PT, TR

Continued on next page...

SEAGULL®
SERIES

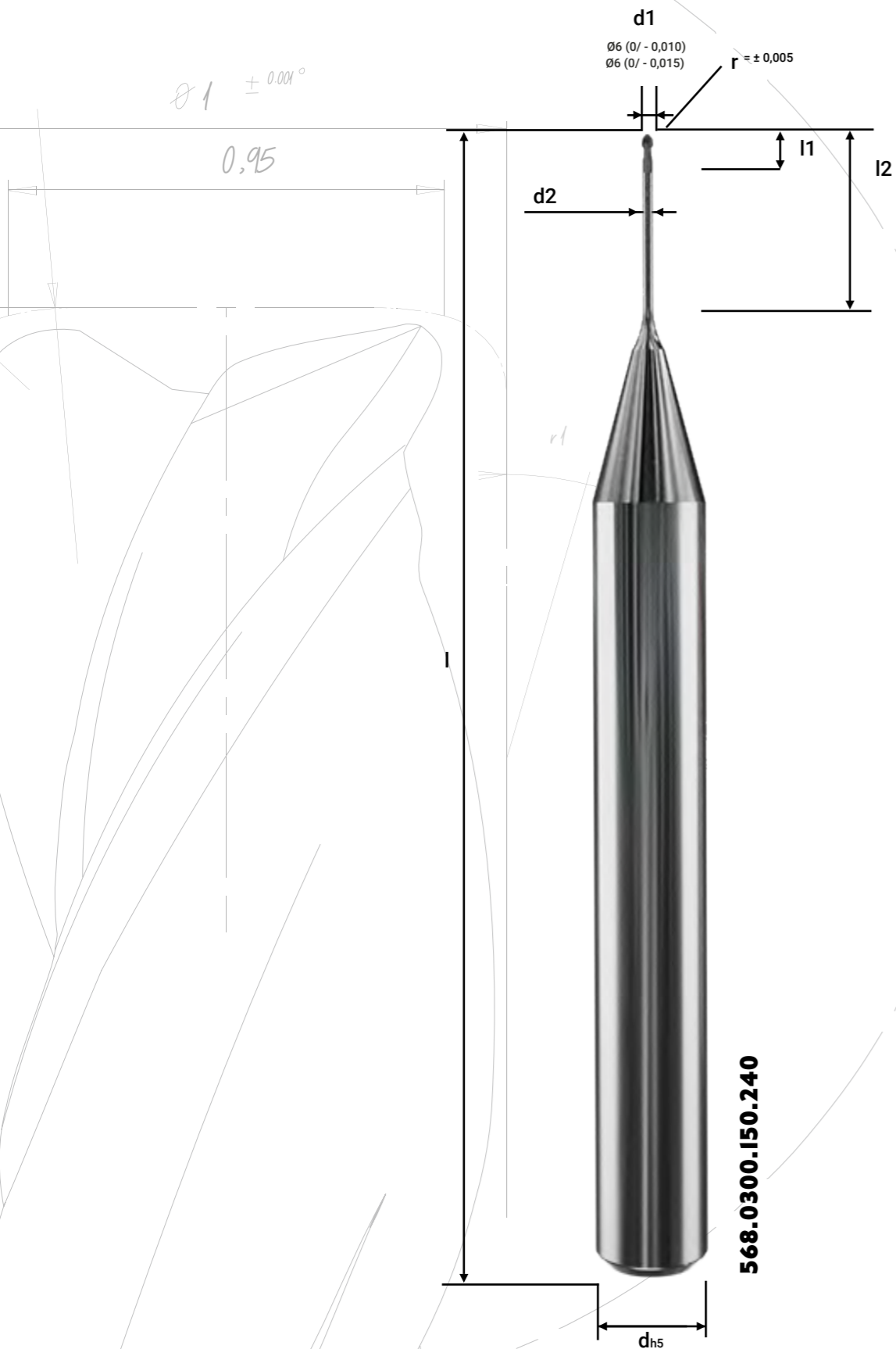

SEAGULL® 568 SERIES...CONTINUED

Article No.	d1	d2	r	l1	l2	d	l
568.0120.060.150	1.2	1.15	0.60	0.90	15.0	4.0	60
568.0120.060.200	1.2	1.15	0.60	0.90	20.0	4.0	60
568.0150.075.100	1.5	1.40	0.75	1.05	10.0	4.0	60
568.0150.075.150	1.5	1.40	0.75	1.05	15.0	4.0	60
568.0150.075.200	1.5	1.40	0.75	1.05	20.0	4.0	60
568.0150.075.250	1.5	1.40	0.75	1.05	25.0	4.0	60
568.0200.100.120	2.0	1.90	1.00	1.30	12.0	4.0	60
568.0200.100.180	2.0	1.90	1.00	1.30	18.0	4.0	60
568.0200.100.200	2.0	1.90	1.00	1.30	20.0	4.0	60
568.0200.100.240	2.0	1.90	1.00	1.30	24.0	4.0	60
568.0200.100.300	2.0	1.90	1.00	1.30	30.0	4.0	60
568.0300.150.120	3.0	2.80	1.50	1.80	12.0	6.0	60
568.0300.150.180	3.0	2.80	1.50	1.80	18.0	6.0	60
568.0300.150.240	3.0	2.80	1.50	1.80	24.0	6.0	60
568.0300.150.300	3.0	2.80	1.50	1.80	30.0	6.0	70
568.0400.200.300	4.0	3.80	2.00	2.50	30.0	6.0	60
568.0400.200.400	4.0	3.80	2.00	2.50	40.0	6.0	70
568.0600.300.450	6.0	5.80	3.00	3.50	45.0	6.0	80
568.0600.300.700	6.0	5.80	3.00	3.50	70.0	6.0	100
568.0800.400.850	8.0	7.80	4.00	4.50	85.0	8.0	120
568.1000.500.850	10.0	9.80	5.00	5.50	85.0	10.0	120

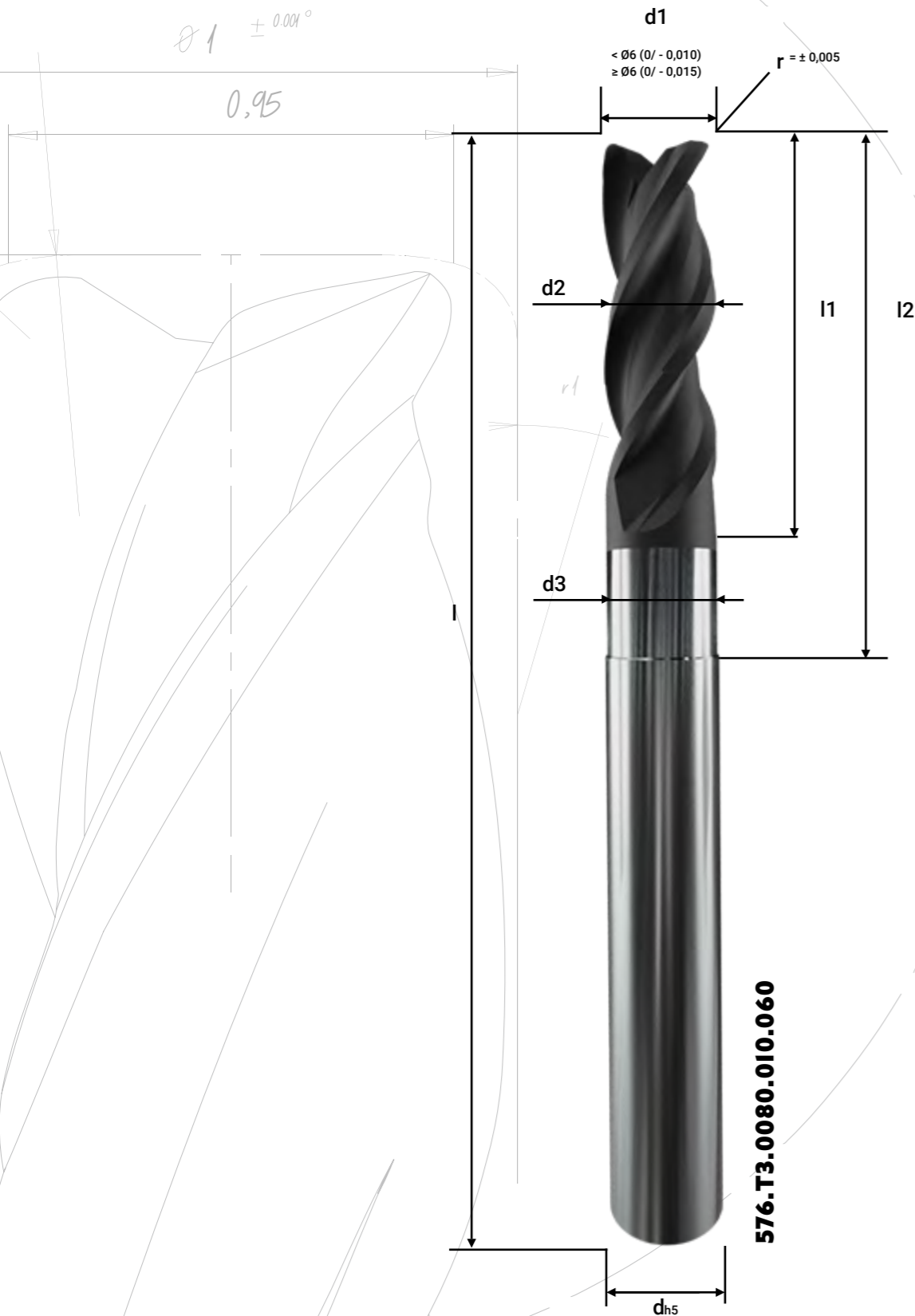

SEAGULL® 576.T3 SERIES

- Solid carbide 3-flute end mill with corner radius and a 30°-38° helix angle
- Patented flute exposure EP 2 540 427 B1*, DE 10 2019 122 039 B3
- Short finishing flute <0.5xD and long roughing flute 2xD
- High-performance diamond coating
- For dry or wet roughing/semi-finishing/finishing



Article No.	d1	d2	d3	r	l1	l2	l3	d	l	Z
576.T3.0030.010.009	0.3	0.27	0.25	0.10	0.25	0.6	0.9	4.0	40	3
576.T3.0030.010.015	0.3	0.27	0.25	0.10	0.25	0.6	1.5	4.0	40	3
576.T3.0030.010.030	0.3	0.27	0.25	0.10	0.25	0.6	3.0	4.0	40	3
576.T3.0040.010.012	0.4	0.37	0.35	0.10	0.25	0.8	1.2	4.0	40	3
576.T3.0040.010.020	0.4	0.37	0.35	0.10	0.25	0.8	2.0	4.0	40	3
576.T3.0040.010.030	0.4	0.37	0.35	0.10	0.25	0.8	3.0	4.0	40	3
576.T3.0050.010.015	0.5	0.45	0.42	0.10	0.30	1.0	1.5	4.0	50	3
576.T3.0050.010.025	0.5	0.45	0.42	0.10	0.30	1.0	2.5	4.0	50	3
576.T3.0050.010.035	0.5	0.45	0.42	0.10	0.30	1.0	3.5	4.0	50	3
576.T3.0050.010.050	0.5	0.45	0.42	0.10	0.30	1.0	5.0	4.0	50	3
576.T3.0060.010.020	0.6	0.55	0.52	0.10	0.30	1.2	2.0	4.0	50	3
576.T3.0060.010.030	0.6	0.55	0.52	0.10	0.30	1.2	3.0	4.0	50	3
576.T3.0060.010.060	0.6	0.55	0.52	0.10	0.30	1.2	6.0	4.0	50	3
576.T3.0060.010.080	0.6	0.55	0.52	0.10	0.30	1.2	8.0	4.0	50	3
576.T3.0080.010.025	0.8	0.75	0.72	0.10	0.30	1.6	2.5	4.0	50	3
576.T3.0080.010.040	0.8	0.75	0.72	0.10	0.30	1.6	4.0	4.0	50	3
576.T3.0080.010.060	0.8	0.75	0.72	0.10	0.30	1.6	6.0	4.0	50	3
576.T3.0080.010.080	0.8	0.75	0.72	0.10	0.30	1.6	8.0	4.0	50	3
576.T3.0100.010.030	1.0	0.93	0.90	0.10	0.40	2.0	3.0	4.0	50	3
576.T3.0100.010.050	1.0	0.93	0.90	0.10	0.40	2.0	5.0	4.0	50	3
576.T3.0100.010.100	1.0	0.93	0.90	0.10	0.40	2.0	10.0	4.0	50	3
576.T3.0100.010.150	1.0	0.93	0.90	0.10	0.40	2.0	15.0	4.0	50	3

*Patented in DE, AT, CH, LIE, CZ, FR, GB, IT, NL, PL, PT, TR

Continued on next page...

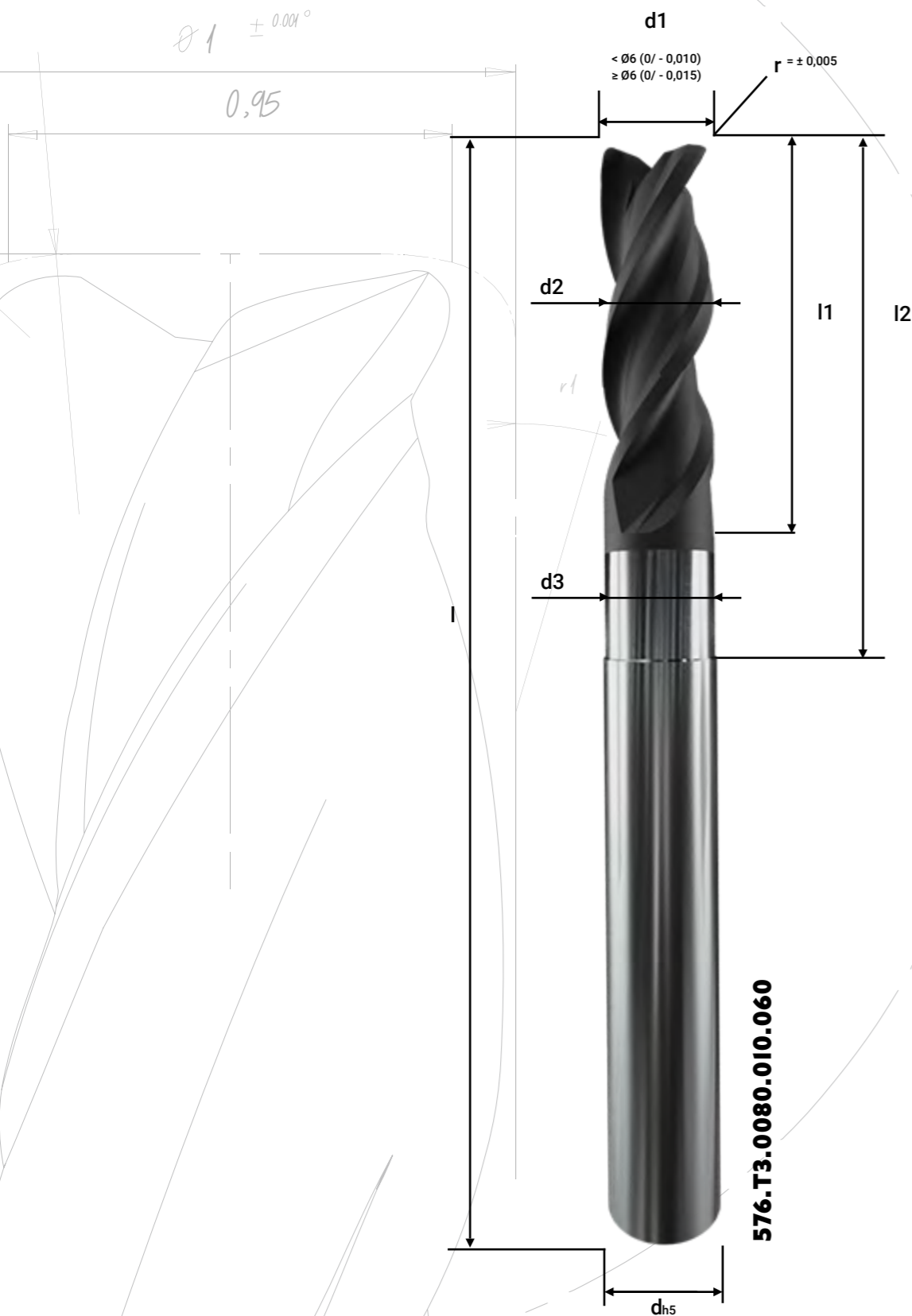

SEAGULL® 576.T3 SERIES...CONTINUED

Article No.	d1	d2	d3	r	l1	l2	l3	d	l	Z
576.T3.0100.020.030	1.0	0.93	0.90	0.20	0.50	2.0	3.0	4.0	50	3
576.T3.0100.020.050	1.0	0.93	0.90	0.20	0.50	2.0	5.0	4.0	50	3
576.T3.0100.020.100	1.0	0.93	0.90	0.20	0.50	2.0	10.0	4.0	50	3
576.T3.0100.020.150	1.0	0.93	0.90	0.20	0.50	2.0	15.0	4.0	50	3
576.T3.0100.020.200	1.0	0.93	0.90	0.20	0.50	2.0	20.0	4.0	50	3
576.T3.0150.010.050	1.5	1.40	1.38	0.10	0.40	3.0	5.0	4.0	50	3
576.T3.0150.010.100	1.5	1.40	1.38	0.10	0.40	3.0	10.0	4.0	50	3
576.T3.0150.010.150	1.5	1.40	1.38	0.10	0.40	3.0	15.0	4.0	50	3
576.T3.0150.010.200	1.5	1.40	1.38	0.10	0.40	3.0	20.0	4.0	50	3
576.T3.0150.015.050	1.5	1.40	1.38	0.15	0.45	3.0	5.0	4.0	50	3
576.T3.0150.015.100	1.5	1.40	1.38	0.15	0.45	3.0	10.0	4.0	50	3
576.T3.0150.015.150	1.5	1.40	1.38	0.15	0.45	3.0	15.0	4.0	50	3
576.T3.0150.015.200	1.5	1.40	1.38	0.15	0.45	3.0	20.0	4.0	50	3
576.T3.0150.020.050	1.5	1.40	1.38	0.20	0.50	3.0	5.0	4.0	50	3
576.T3.0150.020.100	1.5	1.40	1.38	0.20	0.50	3.0	10.0	4.0	50	3
576.T3.0150.020.150	1.5	1.40	1.38	0.20	0.50	3.0	15.0	4.0	50	3
576.T3.0150.020.200	1.5	1.40	1.38	0.20	0.50	3.0	20.0	4.0	50	3
576.T3.0200.010.060	2.0	1.90	1.88	0.10	0.40	4.0	6.0	4.0	50	3
576.T3.0200.010.100	2.0	1.90	1.88	0.10	0.40	4.0	10.0	4.0	50	3
576.T3.0200.010.150	2.0	1.90	1.88	0.10	0.40	4.0	15.0	4.0	50	3
576.T3.0200.010.200	2.0	1.90	1.88	0.10	0.40	4.0	20.0	4.0	50	3
576.T3.0200.010.250	2.0	1.90	1.88	0.10	0.40	4.0	25.0	4.0	50	3
576.T3.0200.020.060	2.0	1.90	1.88	0.20	0.50	4.0	6.0	4.0	50	3
576.T3.0200.020.100	2.0	1.90	1.88	0.20	0.50	4.0	10.0	4.0	50	3
576.T3.0200.020.150	2.0	1.90	1.88	0.20	0.50	4.0	15.0	4.0	50	3
576.T3.0200.020.200	2.0	1.90	1.88	0.20	0.50	4.0	20.0	4.0	50	3
576.T3.0200.020.250	2.0	1.90	1.88	0.20	0.50	4.0	25.0	4.0	50	3
576.T3.0200.030.060	2.0	1.90	1.88	0.30	0.60	4.0	6.0	4.0	50	3
576.T3.0200.030.100	2.0	1.90	1.88	0.30	0.60	4.0	10.0	4.0	50	3
576.T3.0200.030.150	2.0	1.90	1.88	0.30	0.60	4.0	15.0	4.0	50	3
576.T3.0200.030.200	2.0	1.90	1.88	0.30	0.60	4.0	20.0	4.0	50	3
576.T3.0200.030.250	2.0	1.90	1.88	0.30	0.60	4.0	25.0	4.0	50	3
576.T3.0200.050.060	2.0	1.90	1.88	0.50	0.80	4.0	6.0	4.0	50	3
576.T3.0200.050.100	2.0	1.90	1.88	0.50	0.80	4.0	10.0	4.0	50	3

continued on next page...

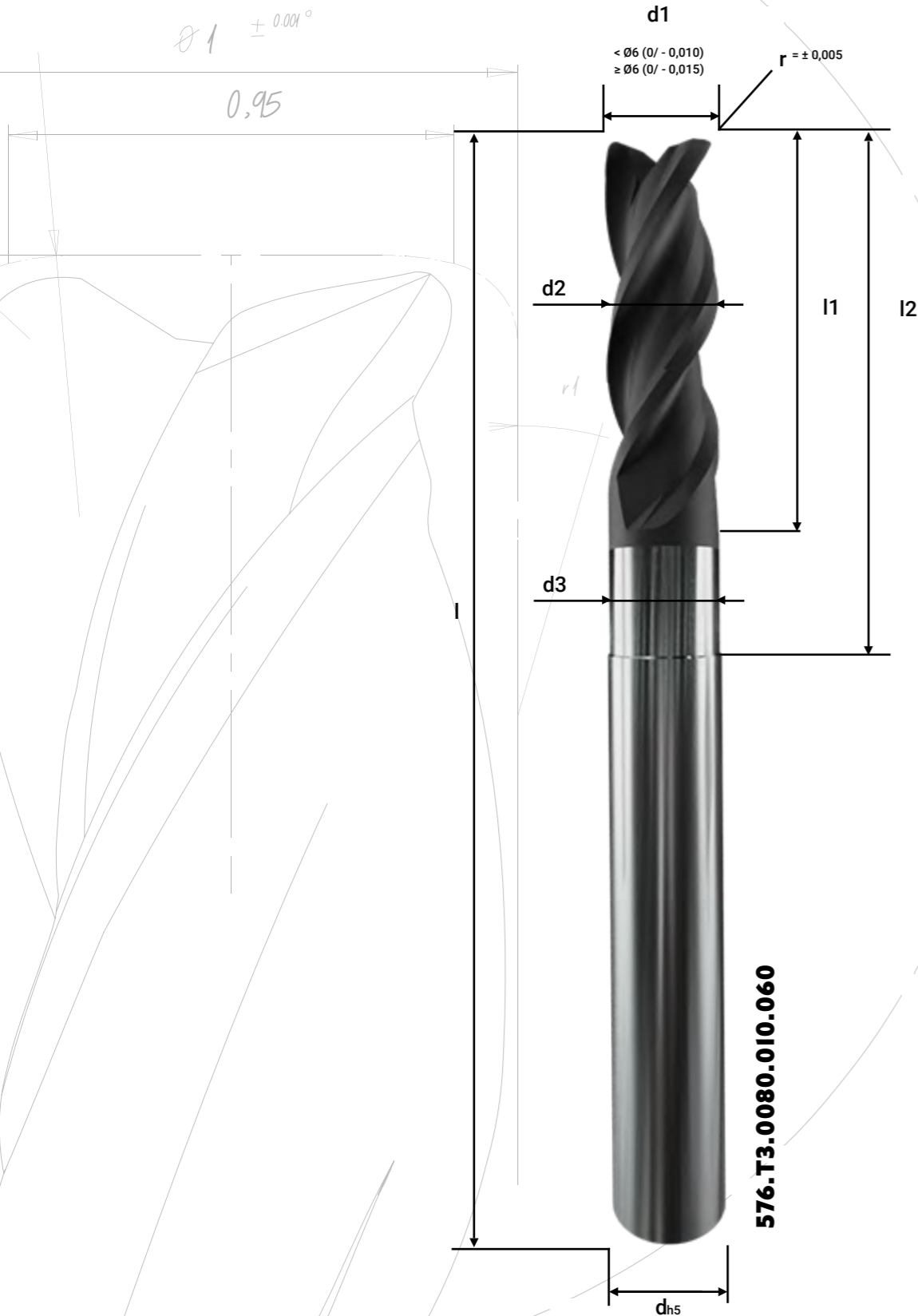

SEAGULL® 576.T3 SERIES...CONTINUED

Article No.	d1	d2	d3	r	l1	l2	l3	d	l	Z
576.T3.0200.050.150	2.0	1.90	1.88	0.50	0.80	4.0	15.0	4.0	50	3
576.T3.0200.050.200	2.0	1.90	1.88	0.50	0.80	4.0	20.0	4.0	50	3
576.T3.0200.050.250	2.0	1.90	1.88	0.50	0.80	4.0	25.0	4.0	50	3
576.T3.0300.010.100	3.0	2.85	2.80	0.10	0.40	6.0	10.0	6.0	60	3
576.T3.0300.010.150	3.0	2.85	2.80	0.10	0.40	6.0	15.0	6.0	60	3
576.T3.0300.010.200	3.0	2.85	2.80	0.10	0.40	6.0	20.0	6.0	60	3
576.T3.0300.010.300	3.0	2.85	2.80	0.10	0.40	6.0	30.0	6.0	60	3
576.T3.0300.020.100	3.0	2.85	2.80	0.20	0.50	6.0	10.0	6.0	60	3
576.T3.0300.020.150	3.0	2.85	2.80	0.20	0.50	6.0	15.0	6.0	60	3
576.T3.0300.020.200	3.0	2.85	2.80	0.20	0.50	6.0	20.0	6.0	60	3
576.T3.0300.020.300	3.0	2.85	2.80	0.20	0.50	6.0	30.0	6.0	60	3
576.T3.0300.030.100	3.0	2.85	2.80	0.30	0.60	6.0	10.0	6.0	60	3
576.T3.0300.030.150	3.0	2.85	2.80	0.30	0.60	6.0	15.0	6.0	60	3
576.T3.0300.030.200	3.0	2.85	2.80	0.30	0.60	6.0	20.0	6.0	60	3
576.T3.0300.030.300	3.0	2.85	2.80	0.30	0.60	6.0	30.0	6.0	60	3
576.T3.0300.050.100	3.0	2.85	2.80	0.50	0.80	6.0	10.0	6.0	60	3
576.T3.0300.050.150	3.0	2.85	2.80	0.50	0.80	6.0	15.0	6.0	60	3
576.T3.0300.050.200	3.0	2.85	2.80	0.50	0.80	6.0	20.0	6.0	60	3
576.T3.0300.050.300	3.0	2.85	2.80	0.50	0.80	6.0	30.0	6.0	60	3
576.T3.0400.020.120	4.0	3.85	3.80	0.20	0.70	8.0	12.0	6.0	60	3
576.T3.0400.020.150	4.0	3.85	3.80	0.20	0.70	8.0	15.0	6.0	60	3
576.T3.0400.020.200	4.0	3.85	3.80	0.20	0.70	8.0	20.0	6.0	60	3
576.T3.0400.020.250	4.0	3.85	3.80	0.20	0.70	8.0	25.0	6.0	60	3
576.T3.0400.020.300	4.0	3.85	3.80	0.20	0.70	8.0	30.0	6.0	60	3
576.T3.0400.030.120	4.0	3.85	3.80	0.30	0.80	8.0	12.0	6.0	60	3
576.T3.0400.030.150	4.0	3.85	3.80	0.30	0.80	8.0	15.0	6.0	60	3
576.T3.0400.030.200	4.0	3.85	3.80	0.30	0.80	8.0	20.0	6.0	60	3
576.T3.0400.030.250	4.0	3.85	3.80	0.30	0.80	8.0	25.0	6.0	60	3
576.T3.0400.030.300	4.0	3.85	3.80	0.30	0.80	8.0	30.0	6.0	60	3
576.T3.0400.050.120	4.0	3.85	3.80	0.50	1.00	8.0	12.0	6.0	60	3
576.T3.0400.050.150	4.0	3.85	3.80	0.50	1.00	8.0	15.0	6.0	60	3
576.T3.0400.050.200	4.0	3.85	3.80	0.50	1.00	8.0	20.0	6.0	60	3
576.T3.0400.050.250	4.0	3.85	3.80	0.50	1.00	8.0	25.0	6.0	60	3

continued on next page...

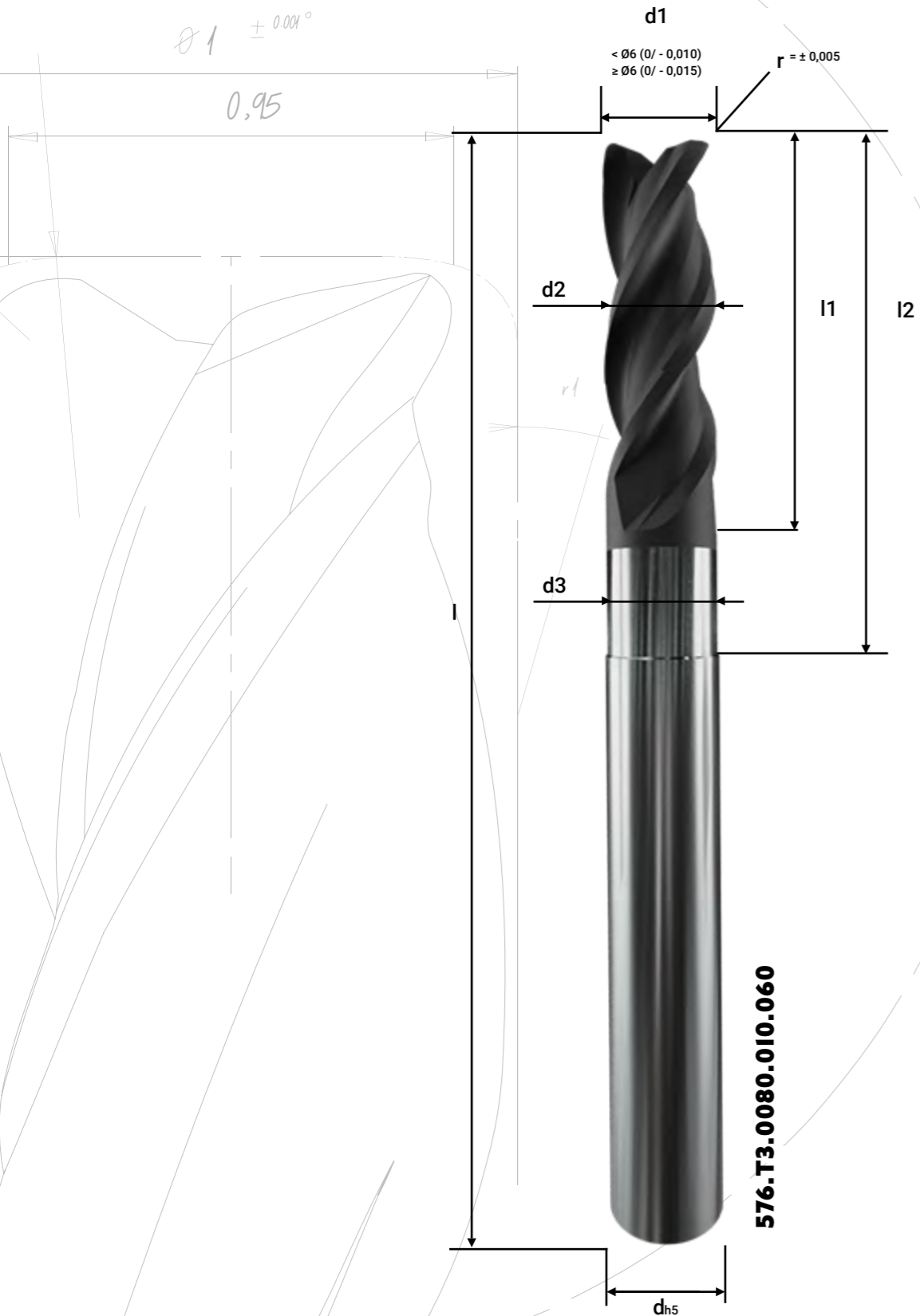

SEAGULL® 576.T3 SERIES...CONTINUED

Article No.	d1	d2	d3	r	l1	l2	l3	d	l	Z
576.T3.0400.050.300	4.0	3.85	3.80	0.50	1.00	8.0	30.0	6.0	60	3
576.T3.0500.030.200	5.0	4.85	4.80	0.30	0.80	10.0	20.0	6.0	60	3
576.T3.0500.030.300	5.0	4.85	4.80	0.30	0.80	10.0	30.0	6.0	60	3
576.T3.0500.030.400	5.0	4.85	4.80	0.30	0.80	10.0	40.0	6.0	80	3
576.T3.0500.030.500	5.0	4.85	4.80	0.30	0.80	10.0	50.0	6.0	80	3
576.T3.0500.050.200	5.0	4.85	4.80	0.50	1.00	10.0	20.0	6.0	60	3
576.T3.0500.050.300	5.0	4.85	4.80	0.50	1.00	10.0	30.0	6.0	60	3
576.T3.0500.050.400	5.0	4.85	4.80	0.50	1.00	10.0	40.0	6.0	80	3
576.T3.0500.050.500	5.0	4.85	4.80	0.50	1.00	10.0	50.0	6.0	80	3
576.T3.0600.020.200	6.0	5.85	5.80	0.20	0.70	12.0	20.0	6.0	60	3
576.T3.0600.020.300	6.0	5.85	5.80	0.20	0.70	12.0	30.0	6.0	60	3
576.T3.0600.020.450	6.0	5.85	5.80	0.20	0.70	12.0	45.0	6.0	100	3
576.T3.0600.020.600	6.0	5.85	5.80	0.20	0.70	12.0	60.0	6.0	100	3
576.T3.0600.030.200	6.0	5.85	5.80	0.30	0.80	12.0	20.0	6.0	60	3
576.T3.0600.030.300	6.0	5.85	5.80	0.30	0.80	12.0	30.0	6.0	60	3
576.T3.0600.030.450	6.0	5.85	5.80	0.30	0.80	12.0	45.0	6.0	100	3
576.T3.0600.030.600	6.0	5.85	5.80	0.30	0.80	12.0	60.0	6.0	100	3
576.T3.0600.050.200	6.0	5.85	5.80	0.50	1.00	12.0	20.0	6.0	60	3
576.T3.0600.050.300	6.0	5.85	5.80	0.50	1.00	12.0	30.0	6.0	60	3
576.T3.0600.050.450	6.0	5.85	5.80	0.50	1.00	12.0	45.0	6.0	100	3
576.T3.0600.050.600	6.0	5.85	5.80	0.50	1.00	12.0	60.0	6.0	100	3

SEAGULL® SERIES

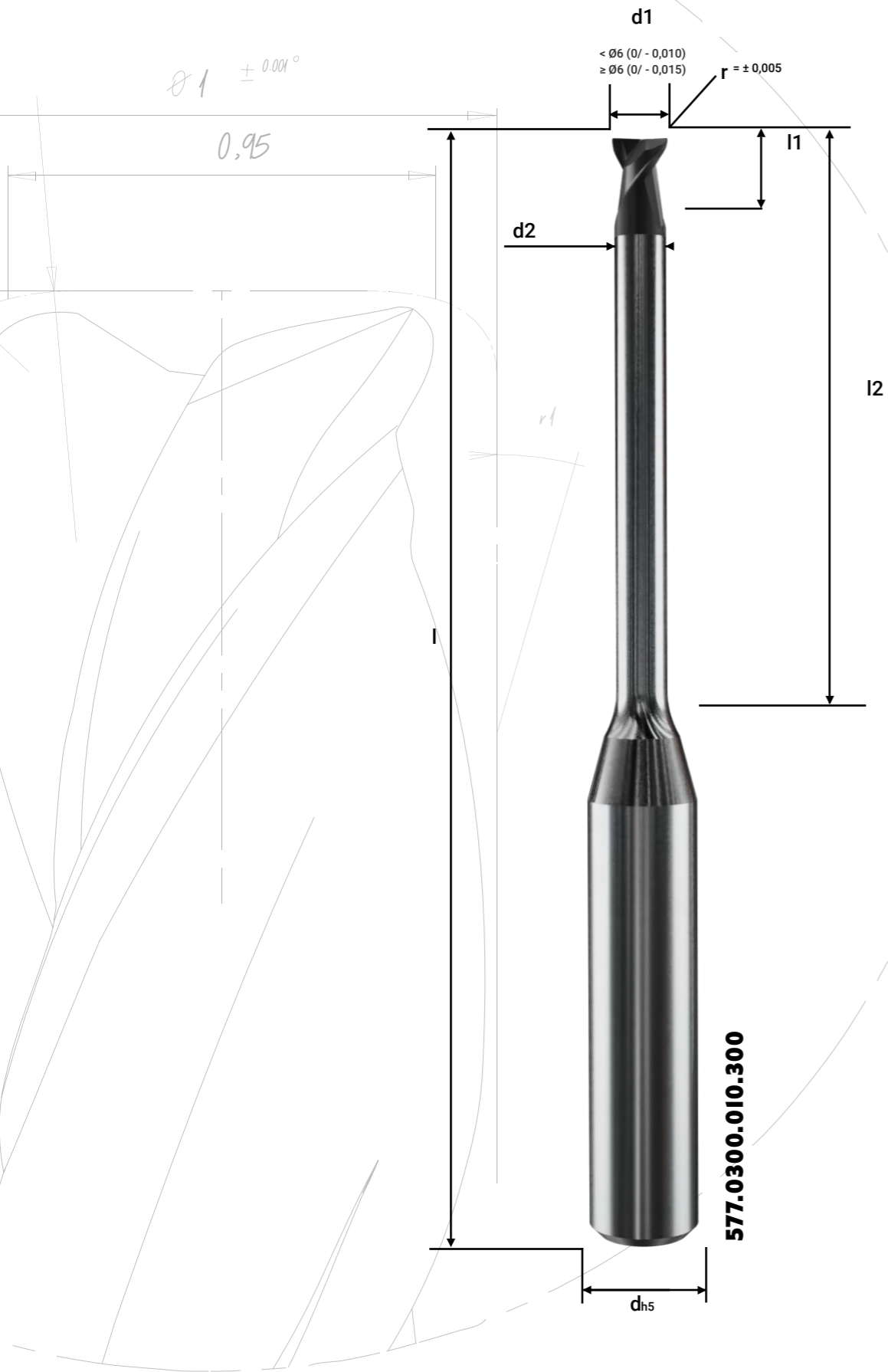

SEAGULL® 577 SERIES

- Solid carbide 2-flute end mill with corner radius and a 30° helix angle
- Patented flute exposure EP 2 540 427 B1*
- Short cutting flute <math>< 0.5 \times D</math>
- High-performance diamond coating
- For dry or wet roughing/semi-finishing/finishing



Article No.	d1	d2	r	l1	l2	d	l
577.0100.010.100	1.0	0.95	0.10	0.40	10.0	4.0	60
577.0200.030.120	2.0	1.90	0.30	0.60	12.0	4.0	60
577.0200.050.120	2.0	1.90	0.50	0.80	12.0	4.0	60
577.0200.030.240	2.0	1.90	0.30	0.60	24.0	4.0	60
577.0200.050.240	2.0	1.90	0.50	0.80	24.0	4.0	60
577.0300.010.180	3.0	2.80	0.10	0.40	18.0	6.0	60
577.0300.050.180	3.0	2.80	0.50	0.80	18.0	6.0	60
577.0300.010.300	3.0	2.80	0.10	0.40	30.0	6.0	60
577.0300.030.300	3.0	2.80	0.30	0.60	30.0	6.0	60
577.0400.020.300	4.0	3.80	0.20	0.50	30.0	6.0	60
577.0400.025.300	4.0	3.80	0.25	0.55	30.0	6.0	60
577.0400.030.300	4.0	3.80	0.30	0.60	30.0	6.0	60
577.0400.050.300	4.0	3.80	0.50	0.80	30.0	6.0	60
577.0400.100.300	4.0	3.80	1.00	1.30	30.0	6.0	60
577.0600.030.450	6.0	5.80	0.30	0.80	45.0	6.0	70
577.0600.050.450	6.0	5.80	0.50	1.00	45.0	6.0	70
577.0600.100.450	6.0	5.80	1.00	1.50	45.0	6.0	70
577.0800.050.400	8.0	7.80	0.50	1.00	40.0	8.0	80
577.0800.100.400	8.0	7.80	1.00	1.50	40.0	8.0	80
577.0800.050.600	8.0	7.80	0.50	1.00	60.0	8.0	100
577.0800.100.600	8.0	7.80	1.00	1.50	60.0	8.0	100
577.0800.050.850	8.0	7.80	0.50	1.00	85.0	8.0	120
577.0800.100.850	8.0	7.80	1.00	1.50	85.0	8.0	120
577.1000.050.700	10.0	9.80	0.50	1.00	70.0	10.0	120
577.1000.100.700	10.0	9.80	1.00	1.50	70.0	10.0	120
577.1000.050.850	10.0	9.80	0.50	1.00	85.0	10.0	120
577.1000.100.850	10.0	9.80	1.00	1.50	85.0	10.0	120
577.1200.100.700	12.0	11.80	1.00	1.50	70.0	12.0	110

*Patented in DE, AT, CH, LIE, CZ, FR, GB, IT, NL, PL, PT, TR

SEAGULL® SERIES

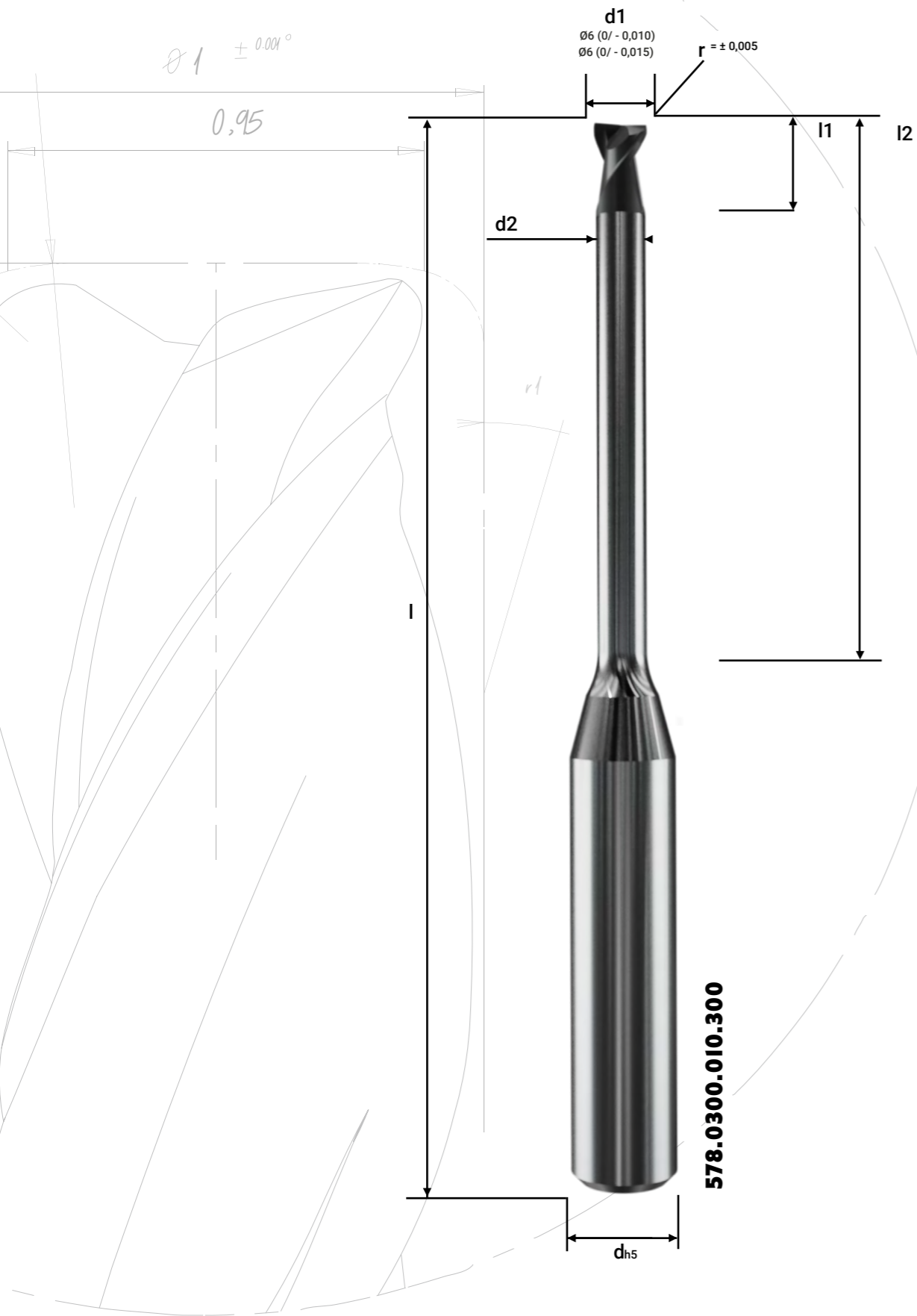

SEAGULL® 578 SERIES

- Solid carbide 2-flute end mill with corner radius and a 30° helix angle
- Patented flute exposure EP 2 540 427 B1*
- Short cutting flute < 0.5 x D (diameter)
- Basic diamond coating
- For dry or wet roughing/semi-finishing/finishing



Article No.	d1	d2	r	l1	l2	d	l
578.0100.010.100	1.0	0.95	0.10	0.40	10.0	4.0	60
578.0200.030.120	2.0	1.90	0.30	0.60	12.0	4.0	60
578.0200.050.120	2.0	1.90	0.50	0.80	12.0	4.0	60
578.0200.030.240	2.0	1.90	0.30	0.60	24.0	4.0	60
578.0200.050.240	2.0	1.90	0.50	0.80	24.0	4.0	60
578.0300.010.180	3.0	2.80	0.10	0.40	18.0	6.0	60
578.0300.050.180	3.0	2.80	0.50	0.80	18.0	6.0	60
578.0300.010.300	3.0	2.80	0.10	0.40	30.0	6.0	60
578.0300.030.300	3.0	2.80	0.30	0.60	30.0	6.0	60
578.0400.020.300	4.0	3.80	0.20	0.50	30.0	6.0	60
578.0400.025.300	4.0	3.80	0.25	0.55	30.0	6.0	60
578.0400.030.300	4.0	3.80	0.30	0.60	30.0	6.0	60
578.0400.050.300	4.0	3.80	0.50	0.80	30.0	6.0	60
578.0400.100.300	4.0	3.80	1.00	1.30	30.0	6.0	60
578.0600.030.450	6.0	5.80	0.30	0.80	45.0	6.0	70
578.0600.050.450	6.0	5.80	0.50	1.00	45.0	6.0	70
578.0600.100.450	6.0	5.80	1.00	1.50	45.0	6.0	70
578.0800.050.400	8.0	7.80	0.50	1.00	40.0	8.0	80
578.0800.100.400	8.0	7.80	1.00	1.50	40.0	8.0	80
578.0800.050.600	8.0	7.80	0.50	1.00	60.0	8.0	100
578.0800.100.600	8.0	7.80	1.00	1.50	60.0	8.0	100
578.0800.050.850	8.0	7.80	0.50	1.00	85.0	8.0	120
578.0800.100.850	8.0	7.80	1.00	1.50	85.0	8.0	120
578.1000.050.700	10.0	9.80	0.50	1.00	70.0	10.0	120
578.1000.100.700	10.0	9.80	1.00	1.50	70.0	10.0	120
578.1000.050.850	10.0	9.80	0.50	1.00	85.0	10.0	120
578.1000.100.850	10.0	9.80	1.00	1.50	85.0	10.0	120
578.1200.100.700	12.0	11.80	1.00	1.50	70.0	12.0	110

*Patented in DE, AT, CH, LIE, CZ, FR, GB, IT, NL, PL, PT, TR

$\varnothing 1 \pm 0.001^{\circ}$
0,95

SERIES OVERVIEW

The SEAGULL® Series has several variations, which we break down below. Here you will find a brief explanation of the tool series as well as relevant symbols for the properties of the tools. More information about the series and a legend to the symbols can be found on the following pages.

Series	Suitable Materials				Suitable Machining Processes							Coating	Tool design					
	Graphite	Zirconium (unsintered)	Carbon	Fiber-reinforced materials	Drilling	Roughing	Pre-Finishing	Finishing	HSC	Dry	Wet	DIA	Geometry	Flutes	Quality line	High-End line	2-in-1 Design	Measurement protocol
567	xx	xx	x	x		x	x	x	x	x	x	xx	Ball	2		x		x
568	xx	xx	x	x		x	x	x	x	x	x	x	Ball	2	x			x
576.T3	xx	xx	x	x		x	x	x	x	x	x	xx	Toric	3			x	x
577	xx	xx	x	x		x	x	x	x	x	x	xx	Toric	2		x		x
578	x	x	x	x		x	x	x	x	x	x	x	Toric	2	x			x

¹ „xx“ indicates that it is optimally designed for processing this material, „x“ indicates that it also works in this material.

² not available for all tools of the series

SEAGULL® SERIES

ICON LEGEND

- White background icons represent Primary Recommended Materials
- Grey background icons represent Secondary Recommended Materials
- Icons to represent tool coating
- Icons to represent the tool design properties
- Icons to represent the indication types of the tool

ICONS

Material Icons

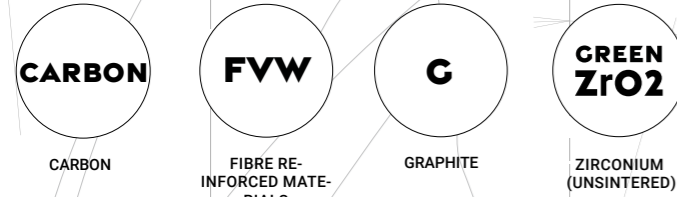

Coating



Tool properties

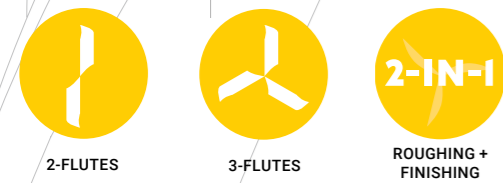

Recommended use



FURTHER INFO

- Careful selection of the VHM grade: Best adhesion and embedding of the CVD diamond layer
- Adjustment of optimal milling parameters: Cutting data calculator for graphite
- Identification by life number: Reproducibility, maintenance of concentricity accuracy through engraving at the bottom of the shaft
- Quality assurance: 100% inspection, actual dimensions on packaging label

AWARD-WINNING: AWARDS FOR OUTSTANDING PERFORMANCE

Only with motivated, positive thinking and independent personalities can a company exist and grow together on new challenges. ZECHA is proud of all its employees for their tireless commitment, passion for progress and willingness to actively contribute to innovation. The awards are the result of creative collaboration and a tribute to the industry.



INNOVATION AWARD OF THE STATE OF BADEN-WÜRTTEMBERG

In 2021, ZECHA Hartmetall-Werkzeugfabrikation GmbH was awarded the Innovation Prize of the State of Baden-Württemberg for the first time. The prize was awarded for the development of a tool family with diamond-coated micro-precision tools that offer outstanding performance in machining the most demanding materials with smooth surfaces. These achievements set new standards worldwide in the field of precision tools.



TOP 100-AWARD

With its outstanding innovation management, ZECHA Hartmetall-Werkzeugfabrikation GmbH receives the TOP 100 seal 2023, an award that is only given to particularly innovative medium-sized companies. The competition is based on a scientific selection process. The decisive factor is whether a company's innovations are random or systematically planned and will be repeatable in the future.

SEAGULL®
SERIES

$\varnothing 1 \pm 0.001^{\circ}$

0,95

Z **ZECHA**
außergewöhnlich.

THE NEW ZECHA BRANDING

Over the years, brands consistently evolve and transform to meet the changing needs and preferences of their consumers. In the competitive landscape of 2024, ZECHA is poised to introduce its new brand identity, marking a significant milestone in its journey. The unveiling of the ZECHA branding represents a culmination of the brand's growth and commitment to excellence.

At the core of the new ZECHA logo lies a perfect circle, which symbolizes the meticulous process of the first step in the process of making all tools at ZECHA, which is grinding tools into flawless cylinders. This iconic image embodies ZECHA's

dedication to precision and quality. It signifies the brand's unwavering pursuit of perfection, ensuring that every tool manufactured by ZECHA is perfectly concentric, guaranteeing superior performance.

In the new branding, ZECHA also integrates the word "außergewöhnlich" into various visuals. Derived from the German language, "außergewöhnlich" translates to "extraordinary" in English. This carefully chosen word encapsulates the overarching goal of every product created by ZECHA. It signifies the brand's commitment to delivering exceptional tools that surpass expectations and set new standards within the industry.

The ZECHA Logo through the years:



∅ 2,02 ±0,02
(∅ 1,57 ±0,02)

TOP
100

top100.de

Top-Innovator
2023

ZECHA'S COMMITMENT TO EXCELENCE

OVER HALF A CENTURY OF PRECISION

ZECHA Hartmetall-Werkzeugfabrikation GmbH is a precision tool manufacturer that has been in Baden-Württemberg, Germany for nearly 60 years. With a focus on manufacturing high quality micro tools, we pride ourselves on providing our customers with the highest level of precision and consistency in our products. Our state-of-the-art manufacturing and measurement technologies allow us to maintain the highest quality standards and ensure that our tools meet our customers' needs.

With a focus on innovation and the constant research of new technologies, we improve the precision and efficiency of our tools. This philosophy allows us to stay at the forefront of the industry and provide our customers with state-of-the-art solutions for their tooling needs.

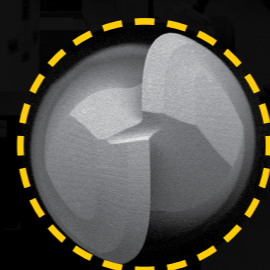

$\varnothing 2,02 \pm 0,02$

$(\varnothing 1,57 \pm 0,02)$

15°



ZECHA

außergewöhnlich.



ZECHA Hartmetall-Werkzeugfabrikation GmbH
Benzstraße 2, D-75203 Königsbach-Stein
+49 7232 3022 0
www.zecha.de, info@zecha.de

